

## N-Channel Enhancement Mode MOSFET

### Features

- 30V/100A,  
 $R_{DS(ON)} = 4.0m\Omega(max.) @ V_{GS} = 10V$   
 $R_{DS(ON)} = 7.5m\Omega(max.) @ V_{GS} = 4.5V$
- Avalanche Rated
- 100% UIS +  $R_g$  Tested
- Reliable and Rugged
- Lead Free and Green Devices Available  
 (RoHS Compliant)

### Applications

- Power Management in Notebook Computer, Portable Equipment and Battery Powered Systems.

### Pin Description

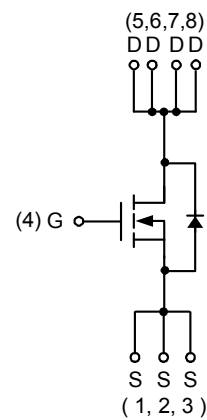
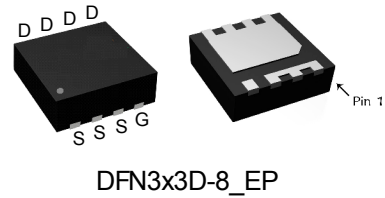

N-Channel MOSFET

## Absolute Maximum Ratings ( $T_A = 25^\circ\text{C}$ Unless Otherwise Noted)

Symbol	Parameter	Rating	Unit	
$V_{DSS}$	Drain-Source Voltage	30	V	
$V_{GSS}$	Gate-Source Voltage	$\pm 20$		
$I_D^a$	Continuous Drain Current ( $V_{GS}=10\text{V}$ )	$T_A=25^\circ\text{C}$	12	A
		$T_A=70^\circ\text{C}$	9.5	
$I_{DM}^a$	Pulsed Drain Current ( $V_{GS}=10\text{V}$ )	$T_A=25^\circ\text{C}$	40	
$I_D^d$	Continuous Drain Current ( $V_{GS}=10\text{V}$ )	$T_C=25^\circ\text{C}$	85	
		$T_C=70^\circ\text{C}$	42	
$I_{DM}$	Pulsed Drain Current ( $V_{GS}=10\text{V}$ )	$T_C=25^\circ\text{C}$	110	
$I_S$	Diode Continuous Forward Current	40		
$I_{AS}^b$	Avalanche Current, Single pulse	$L=0.1\text{mH}$	25	
$E_{AS}^b$	Avalanche Energy, Single pulse	$L=0.1\text{mH}$	31.25	mJ
$T_J$	Maximum Junction Temperature	150	$^\circ\text{C}$	
$T_{STG}$	Storage Temperature Range	-55 to 150		
$P_D^a$	Maximum Power Dissipation	$T_A=25^\circ\text{C}$	1.6	W
		$T_A=70^\circ\text{C}$	1	
$P_D^d$	Maximum Power Dissipation	$T_C=25^\circ\text{C}$	29	W
		$T_C=70^\circ\text{C}$	19	
$R_{\theta JA}^{a,c}$	Thermal Resistance-Junction to Ambient	$t \leq 10\text{s}$	35	$^\circ\text{C/W}$
		Steady State	60	
$R_{\theta JC}^d$	Thermal Resistance-Junction to Case	Steady State	3.5	

Note a : Surface Mounted on  $1\text{in}^2$  pad area,  $t \leq 10\text{sec}$ .

Note b : UIS tested and pulse width limited by maximum junction temperature  $150^\circ\text{C}$  (initial temperature  $T_J=25^\circ\text{C}$ ).

Note c : Maximum under Steady State conditions is  $75^\circ\text{C/W}$ .

Note d : The power dissipation  $P_D$  is based on  $T_{J(\text{MAX})} = 150^\circ\text{C}$ , and it is useful for reducing junction-to-case thermal resistance ( $R_{\theta JC}$ ) when additional heat sink is used.

## Electrical Characteristics (T<sub>A</sub> = 25°C Unless Otherwise Noted)

Symbol	Parameter	Test Conditions	Min.	Typ.	Max.	Unit
<b>Static Characteristics</b>						
BV <sub>DSS</sub>	Drain-Source Breakdown Voltage	V <sub>GS</sub> =0V, I <sub>DS</sub> =250μA	30	-	-	V
I <sub>DSS</sub>	Zero Gate Voltage Drain Current	V <sub>DS</sub> =24V, V <sub>GS</sub> =0V	-	-	1	μA
		T <sub>J</sub> =85°C	-	-	30	
V <sub>GS(th)</sub>	Gate Threshold Voltage	V <sub>DS</sub> =V <sub>GS</sub> , I <sub>DS</sub> =250μA	1.5	1.8	2.5	V
I <sub>GSS</sub>	Gate Leakage Current	V <sub>GS</sub> =±20V, V <sub>DS</sub> =0V	-	-	±100	nA
R <sub>DS(ON)</sub> <sup>a</sup>	Drain-Source On-state Resistance	V <sub>GS</sub> =10V, I <sub>DS</sub> =12A	-	4.0	5.5	mΩ
		V <sub>GS</sub> =4.5V, I <sub>DS</sub> =9A	-	6.3	7.5	
<b>Diode Characteristics</b>						
V <sub>SD</sub> <sup>a</sup>	Diode Forward Voltage	I <sub>SD</sub> =2A, V <sub>GS</sub> =0V	-	0.8	1.1	V
t <sub>rr</sub> <sup>b</sup>	Reverse Recovery Time	I <sub>SD</sub> =12A, dI <sub>SD</sub> /dt=100A/μs	-	10	-	ns
t <sub>a</sub>	Charge Time		-	7	-	
t <sub>b</sub>	Discharge Time		-	2.7	-	
Q <sub>rr</sub> <sup>b</sup>	Reverse Recovery Charge		-	3	-	
<b>Dynamic Characteristics<sup>b</sup></b>						
R <sub>G</sub>	Gate Resistance	V <sub>GS</sub> =0V, V <sub>DS</sub> =0V, F=1MHz	-	3	4.5	Ω
C <sub>iss</sub>	Input Capacitance	V <sub>GS</sub> =0V, V <sub>DS</sub> =15V, Frequency=1.0MHz	560	1100	1540	pF
C <sub>oss</sub>	Output Capacitance		185	265	345	
C <sub>rss</sub>	Reverse Transfer Capacitance		99	105	231	
t <sub>d(ON)</sub>	Turn-on Delay Time	V <sub>DD</sub> =15V, R <sub>L</sub> =15Ω, I <sub>DS</sub> =1A, V <sub>GEN</sub> =10V, R <sub>G</sub> =6Ω	-	14	26	ns
t <sub>r</sub>	Turn-on Rise Time		-	10	19	
t <sub>d(OFF)</sub>	Turn-off Delay Time		-	44	80	
t <sub>f</sub>	Turn-off Fall Time		-	12	23	
<b>Gate Charge Characteristics<sup>b</sup></b>						
Q <sub>g</sub>	Total Gate Charge	V <sub>DS</sub> =15V, V <sub>GS</sub> =10V, I <sub>DS</sub> =12A	-	28.3	39.6	nC
Q <sub>g</sub>	Total Gate Charge	V <sub>DS</sub> =15V, V <sub>GS</sub> =4.5V, I <sub>DS</sub> =12A	-	12.9	18	
Q <sub>gth</sub>	Threshold Gate Charge		-	2.46	3.44	
Q <sub>gs</sub>	Gate-Source Charge		-	4.22	5.9	
Q <sub>gd</sub>	Gate-Drain Charge		-	7.3	10.2	

Note a : Pulse test ; pulse width ≤ 300 μs, duty cycle ≤ 2%.

Note b : Guaranteed by design, not subject to production testing.

## Typical Operating Characteristics

Power Dissipation

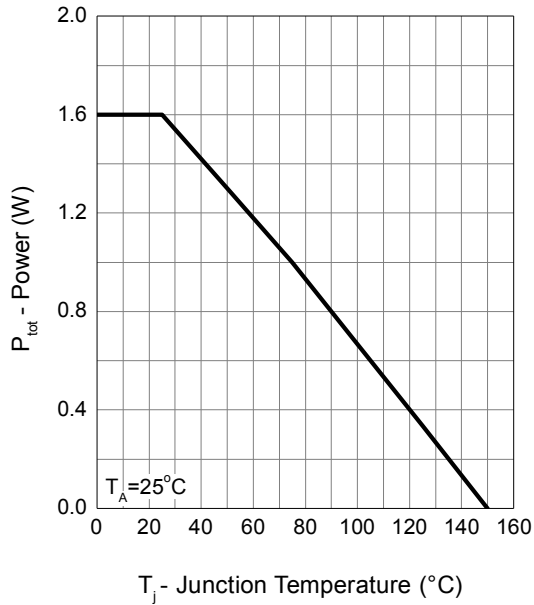

Drain Current

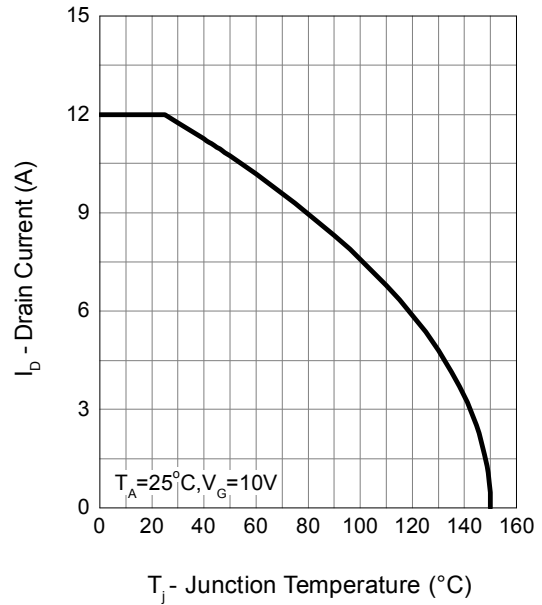

Safe Operation Area

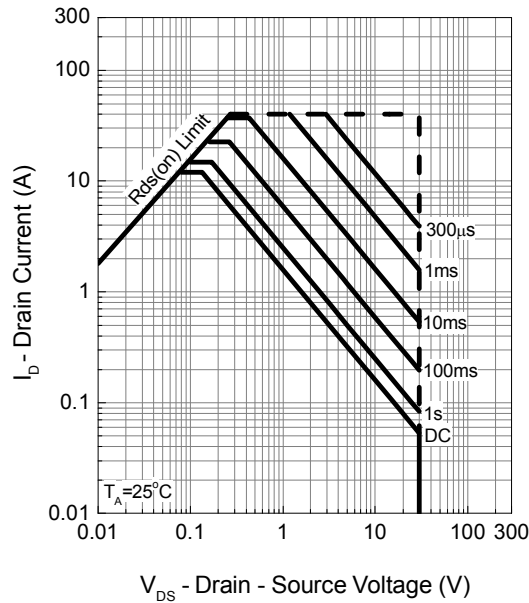

Safe Operation Area

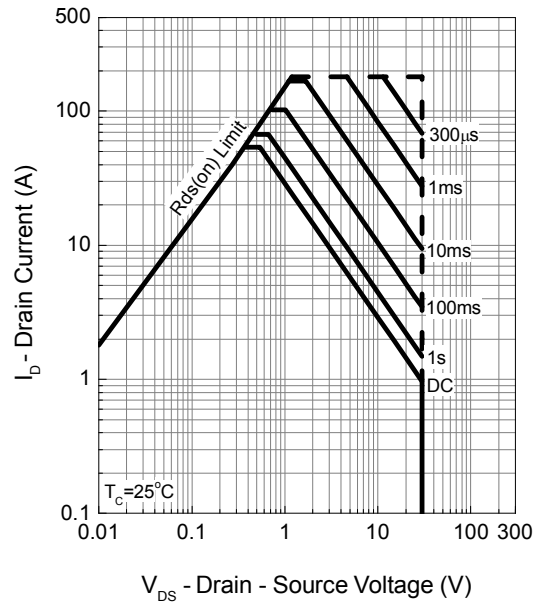

## Typical Operating Characteristics (Cont.)

**Thermal Transient Impedance**

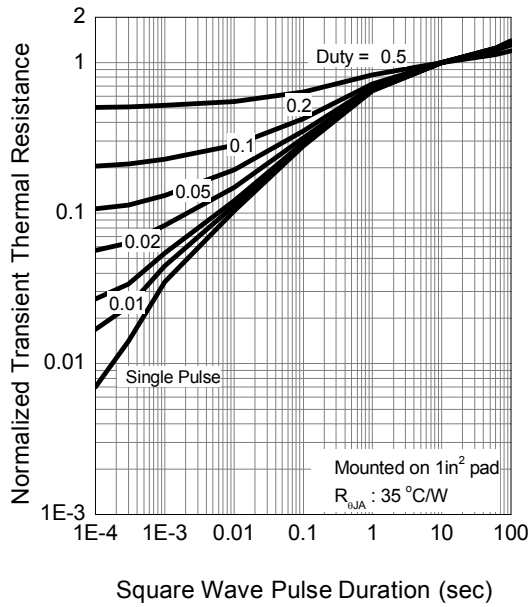

**Output Characteristics**

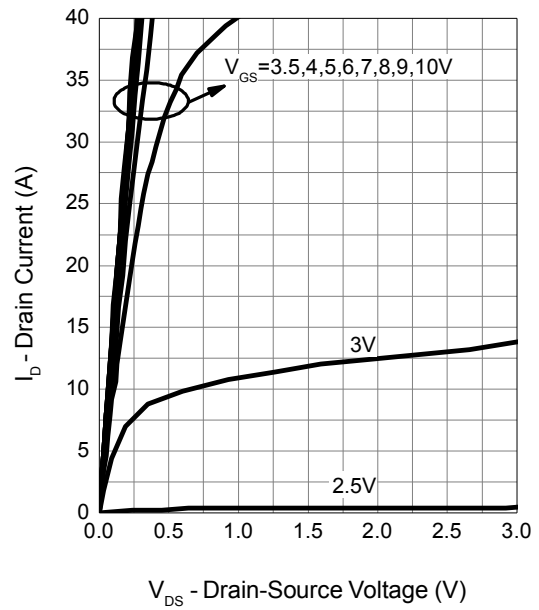

**Drain-Source On Resistance**

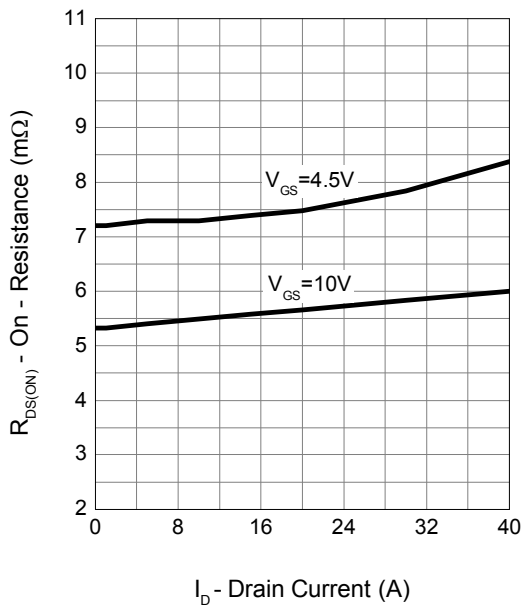

**Gate-Source On Resistance**

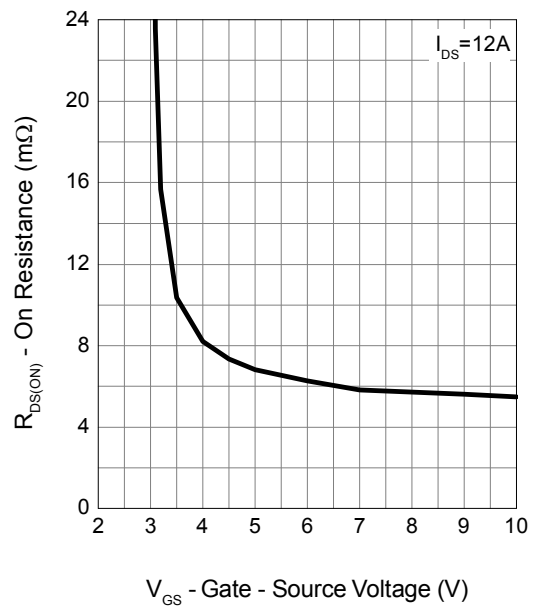

## Typical Operating Characteristics (Cont.)

**Gate Threshold Voltage**

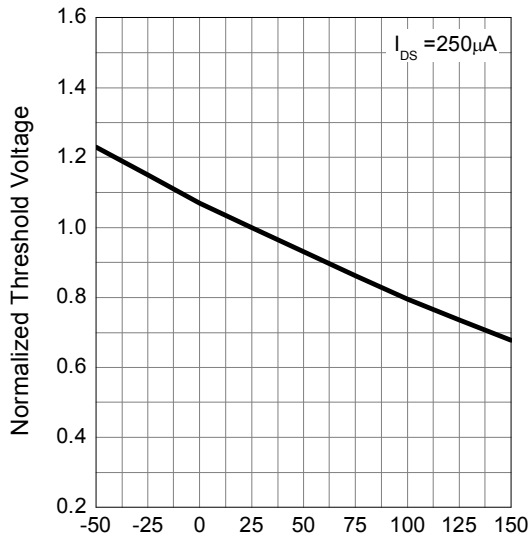

$T_j$  - Junction Temperature ( $^{\circ}\text{C}$ )

**Drain-Source On Resistance**

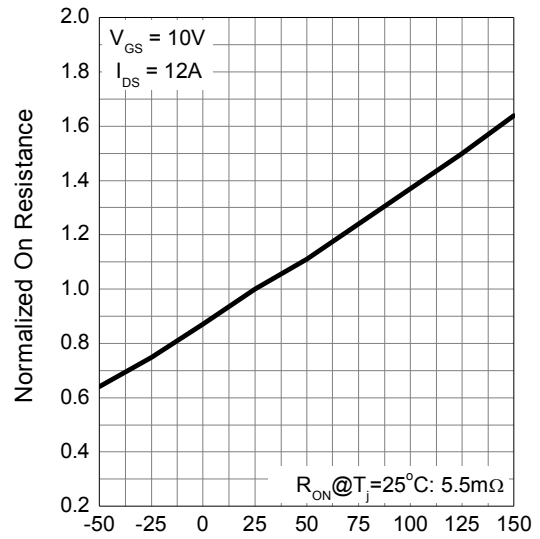

$T_j$  - Junction Temperature ( $^{\circ}\text{C}$ )

**Source-Drain Diode Forward**

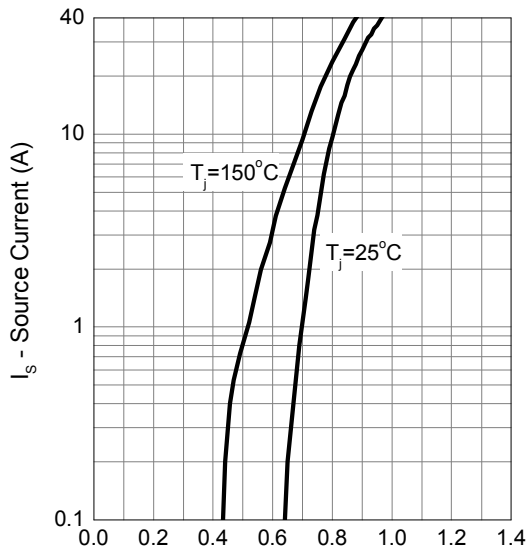

$V_{SD}$  - Source - Drain Voltage (V)

**Capacitance**

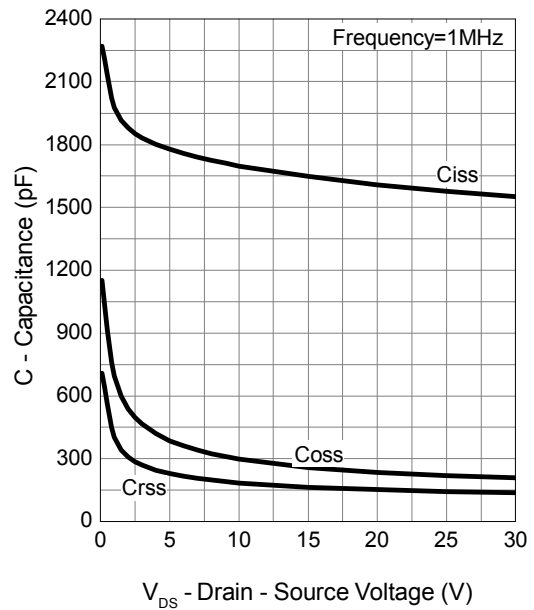

$V_{DS}$  - Drain - Source Voltage (V)

## Typical Operating Characteristics (Cont.)

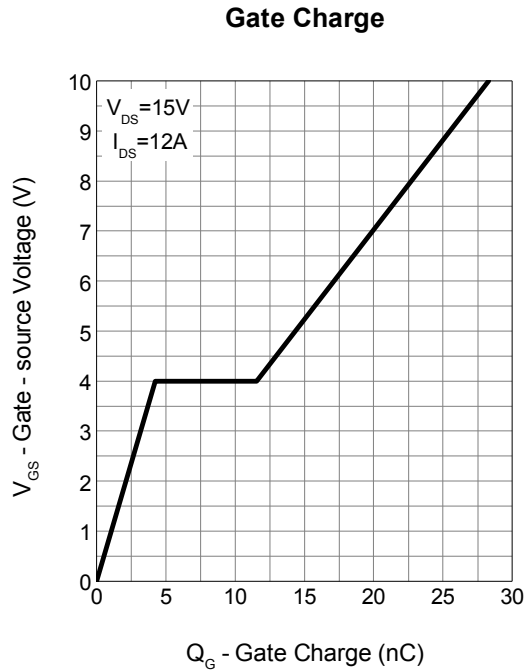

## Avalanche Test Circuit and Waveforms

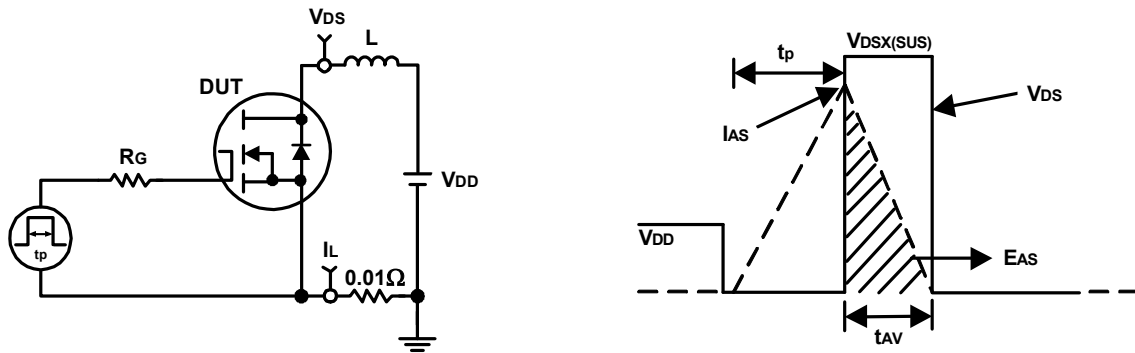

## Switching Time Test Circuit and Waveforms

