

SOT-23 Plastic-Encapsulate MOSFETS

MMBTA56 TRANSISTOR (PNP)

MARKING:

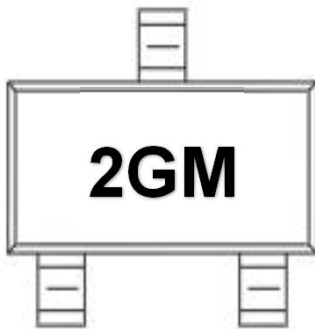

Equivalent Circuit:

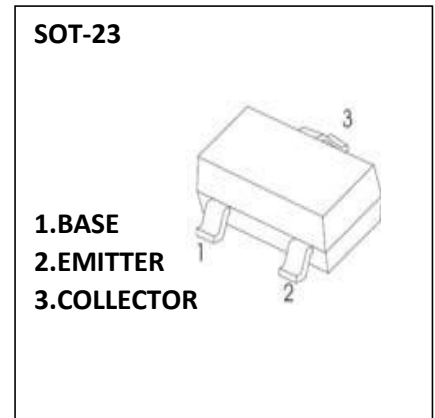
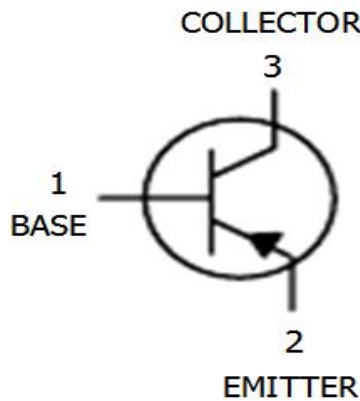

FEATURES:

- ※ Complimentary Type NPN Transistor MMBTA06
- ※ General Purpose Amplifier Applications

MAXIMUM RATINGS (Ta=25°C unless otherwise noted)

Parameter	Symbol	Value	Unit
Collector-Base Voltage	VCBO	-80	V
Collector-Emitter Voltage	VCEO	-80	V
Emitter-Base Voltage	VEBO	-4	V
Collector Current	IC	-500	mA
Collector Power Dissipation	PC	225	mW
Thermal Resistance From Junction To Ambient	ROJA	555	°C/W
Junction Temperature	Tj	150	°C
Storage Temperature	Tstg	-55~+150	°C

ELECTRICAL CHARACTERISTICS (Ta=25°C unless otherwise specified)

Parameter	Symbol	Test Condition	Min	Typ	Max	Unit
Collector-base breakdown voltage	V(BR)CBO	IC= -100μA, IE=0	-80			V
Collector-emitter breakdown voltage	V(BR)CEO	IC= -1mA, IB=0	-80			V
Emitter-base breakdown voltage	V(BR)EBO	IE=-100μA, IC=0	-4			V
Collector cut-off current	ICBO	VCB=-80 V , IE=0			-0.1	μA
Collector cut-off current	ICEO	VCB=-60V , IE=0			-1	μA
Emitter cut-off current	IEBO	VEB= -3V , IC=0			-0.1	μA
DC current gain	hFE	VCE=-1V, IC= -10mA	100		400	
	hFE	VCE=-1V, IC= -100mA	100			
Collector-emitter saturation voltage	VCE(sat)	IC=-100 mA, IB= -10mA			-0.25	V
Base-emitter saturation voltage	VBE(sat)	VCE=-1V, IC=-100mA			-1.2	V
Transition frequency	fT	VCE=-1V, IC= -100mA f=100MHz	50			MHz

CLASSIFICATION OF hFE

Rank	L	H	G
Range	100-200	200-300	300-400

TYPICAL ELECTRICAL AND THERMAL CHARACTERISTICS

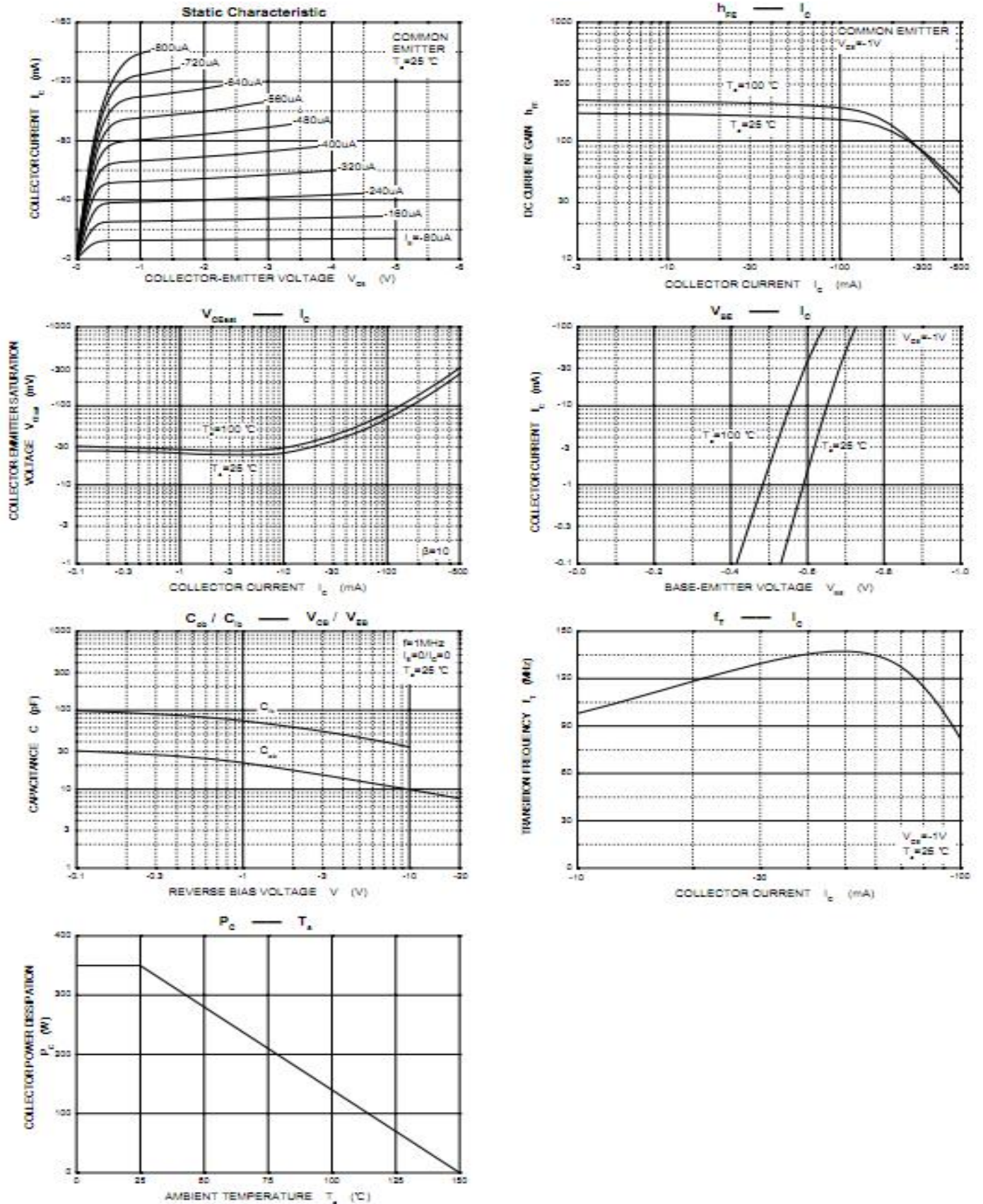

SOT-23 PACKAGE OUTLINE DIMENSIONS

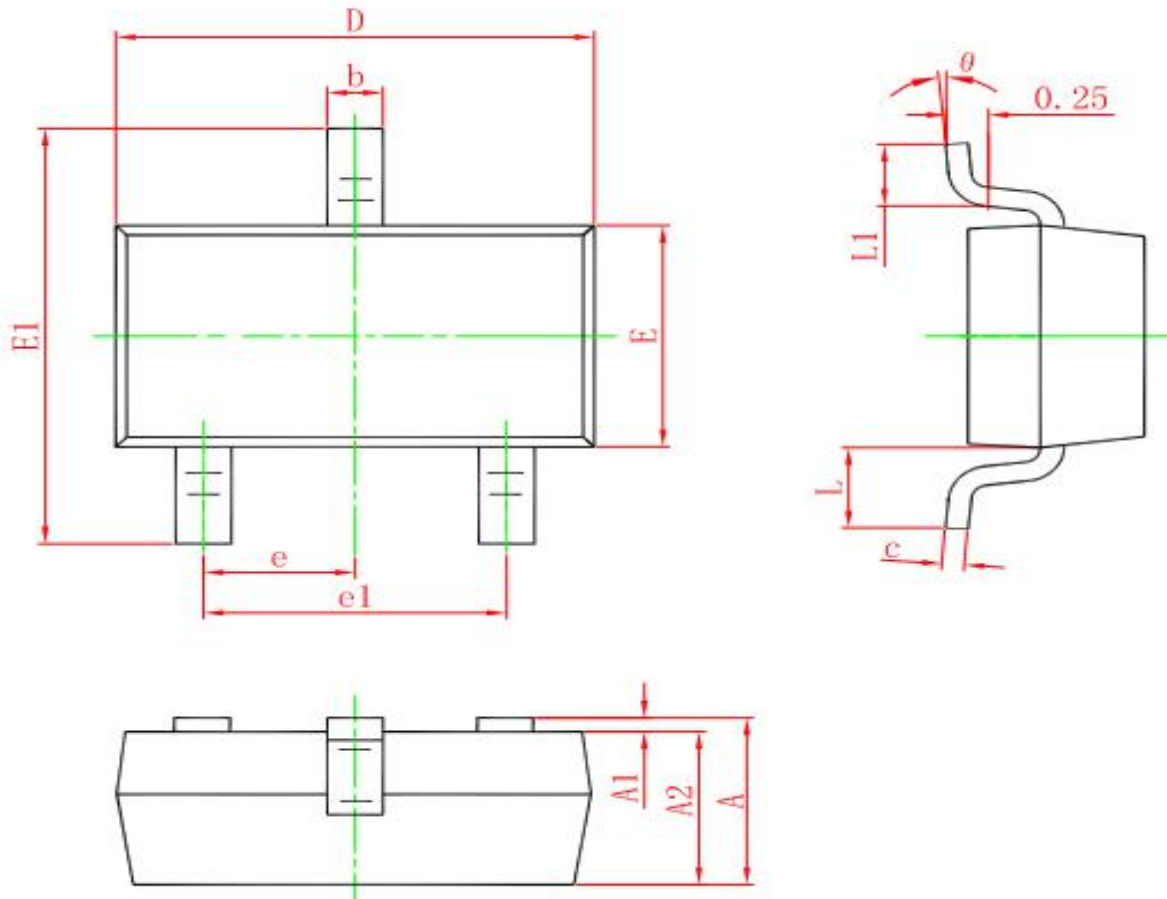

Symbol	Dimensions In Millimeters		Dimensions In Inches	
	Min.	Max.	Min.	Max.
A	0.900	1.150	0.035	0.045
A1	0.000	0.100	0.000	0.004
A2	0.900	1.050	0.035	0.041
b	0.300	0.500	0.012	0.020
c	0.080	0.150	0.003	0.006
D	2.800	3.000	0.110	0.118
E	1.200	1.400	0.047	0.055
E1	2.250	2.550	0.089	0.100
e	0.950 TYP.		0.037 TYP.	
e1	1.800	2.000	0.071	0.079
L	0.550 REF.		0.022 REF.	
L1	0.300	0.500	0.012	0.020
θ	0°	8°	0°	8°