

SOT-23 Plastic-Encapsulate MOSFETS

2SC2714 TRANSISTOR (NPN)

MARKING:

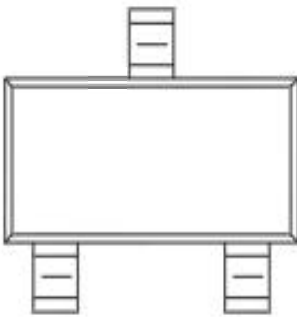

Equivalent Circuit

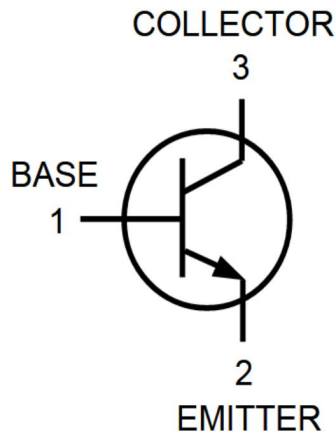

SOT-23

- 1.BASE
- 2.EMITTER
- 3.COLLECTOR

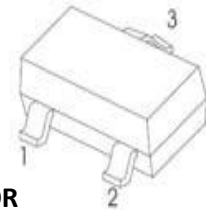

FEATURES:

- Small reverse Transfer Capacitance: $C_{re}=0.7\text{pF}$ (typ.)
- Low Noise Figure: $NF=2.5\text{dB}$ (typ.) ($f=100\text{MHz}$)

MAXIMUM RATINGS ($T_a=25^\circ\text{C}$ unless otherwise noted)

Parameter	Symbol	Value	Unit
Collector-Base Voltage	VCBO	40	V
Collector-Emitter Voltage	VCEO	30	V
Emitter-Base Voltage	VEBO	4	V
Collector Current -Continuous	IC	20	mA
Collector Current -Pulsed	ICM	100	mA
Collector Power Dissipation	PC	100	mW
Thermal Resistance From Junction To Ambient	R θ JA	1000	$^\circ\text{C}/\text{W}$
Junction Temperature	Tj	125	$^\circ\text{C}$
Storage Temperature	Tstg	-55~+125	$^\circ\text{C}$

ELECTRICAL CHARACTERISTICS (Ta=25°C unless otherwise specified)

Parameter	Symbol	Test Condition	Min	Typ	Max	Unit
Collector-base breakdown voltage	V(BR)CBO	IC= 10μA, IE=0	40			V
Collector-emitter breakdown voltage	V(BR)CEO	IC= 1mA, IB=0	30			V
Emitter-base breakdown voltage	V(BR)EBO	IE=10μA, IC=0	4			V
Collector cut-off current	ICBO	VCB= 18 V , IE=0			0.5	μA
Collector cut-off current	ICEO	VCB= 15V , IE=0			0.5	μA
Emitter cut-off current	IEBO	VEB= 4V , IC=0			0.5	μA
DC current gain	hFE	VCE= 6V, IC= 1mA	40		200	
	hFE	VCE= 6V, IC= 10mA	50			
Transition frequency	fT	VCE= 6V, IC= 1mA f=400MHz		550		MHz
Reverse Transfer capacitance	Cre	VCB=6V,IE=0,f=1MHz		0.7		PF
Noise figure	NF	VE=6V,Ic=1mA,f=100MHz		2.5	5	dB

CLASSIFICATION OF hFE

Rank	R	O	Y
Range	40-80	70-140	100-200
Marking	QR	QO	QY

TYPICAL ELECTRICAL AND THERMAL CHARACTERISTICS

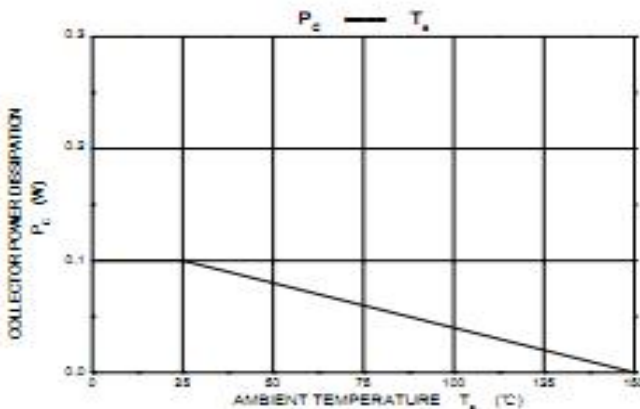
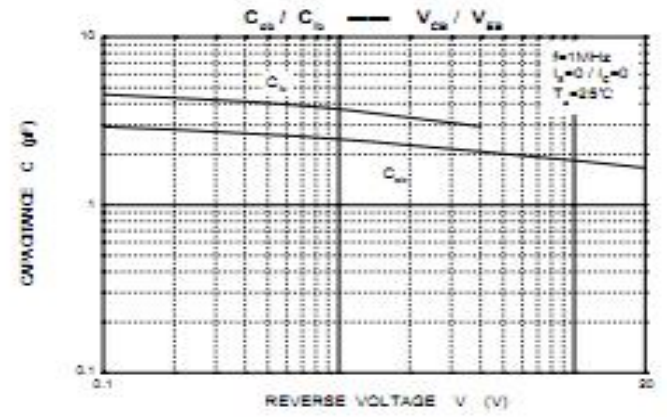
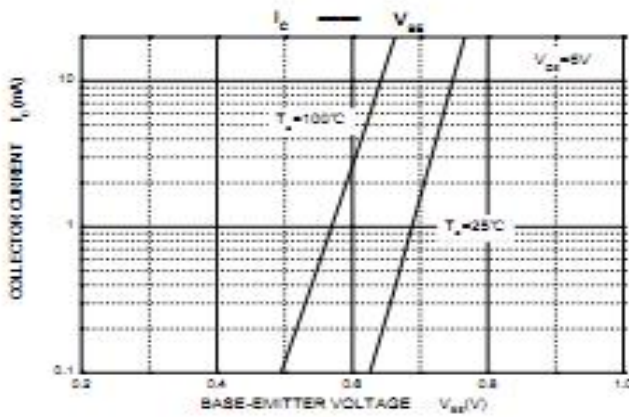
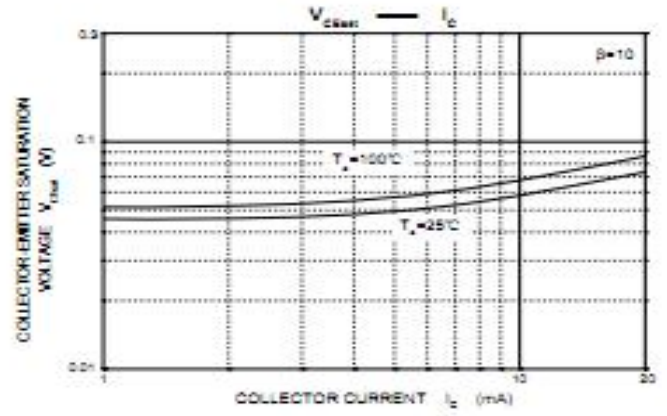
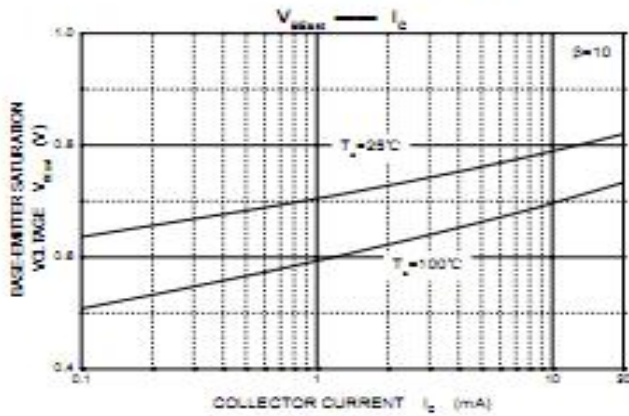
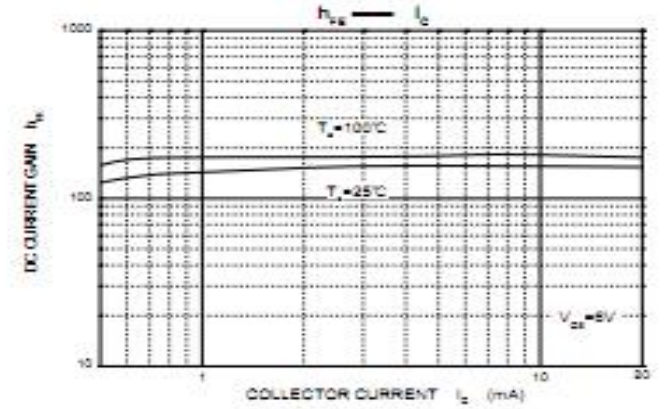
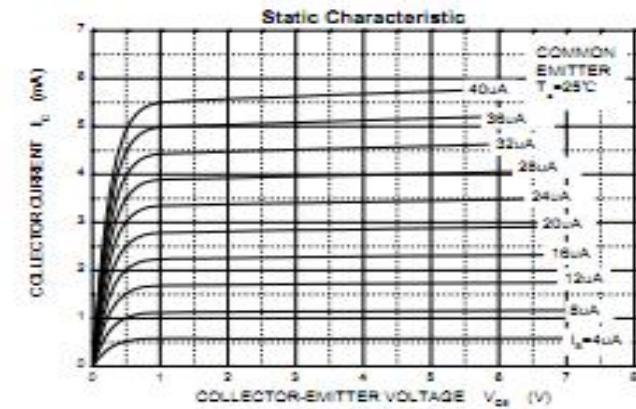

SOT-23 PACKAGE OUTLINE DIMENSIONS

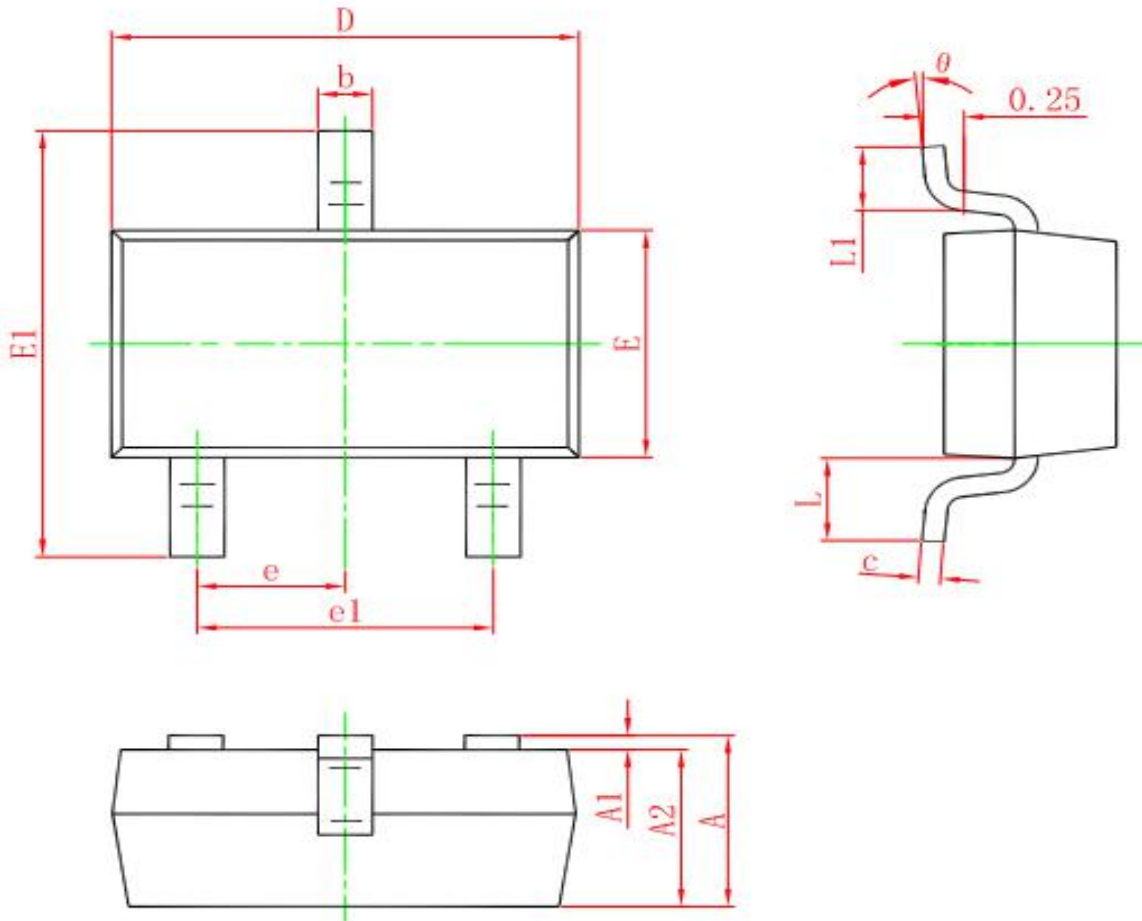

Symbol	Dimensions In Millimeters		Dimensions In Inches	
	Min.	Max.	Min.	Max.
A	0.900	1.150	0.035	0.045
A1	0.000	0.100	0.000	0.004
A2	0.900	1.050	0.035	0.041
b	0.300	0.500	0.012	0.020
c	0.080	0.150	0.003	0.006
D	2.800	3.000	0.110	0.118
E	1.200	1.400	0.047	0.055
E1	2.250	2.550	0.089	0.100
e	0.950 TYP.		0.037 TYP.	
e1	1.800	2.000	0.071	0.079
L	0.550 REF.		0.022 REF.	
L1	0.300	0.500	0.012	0.020
θ	0°	8°	0°	8°