

## -30V P-Channel Fast Switching MOSFETs

### ■ DESCRIPTION

The 4407A is the P-Channel logic enhancement mode power field effect transistor is produced using high cell density advanced trench technology..

This high density process is especially tailored to minimize on-state resistance.

This device is suitable for use as a load switch or in PWM and gate charge for most of the synchronous buck converter applications

### ■ FEATURE

- ◆ -30V/-13A,  $R_{DS(ON)} < 10m\Omega$  (typ.)@ $V_{GS} = -10V$
- ◆ -30V/-7.0A,  $R_{DS(ON)} < 14.5m\Omega$  (typ.)@ $V_{GS} = -4.5V$
- ◆ Super high design for extremely low  $R_{DS(ON)}$
- ◆ Exceptional on-resistance and Maximum DC current capability
- ◆ Full RoHS compliance
- ◆ SOP8 package design

### ■ APPLICATIONS

- ◆ High Frequency Point-of-Load Synchronous Buck Converter for MB/NB/UMPC/GA
- ◆ Newworking DC-DC Power System
- ◆ Load Switch
- ◆ Power Management in Note Book

### ■ PIN CONFIGURATION

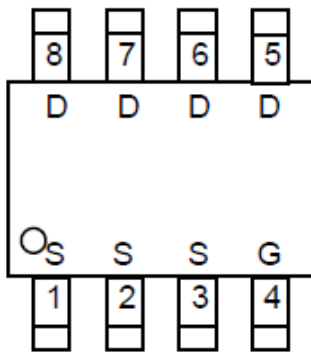

TOP VIEW  
SOP-8

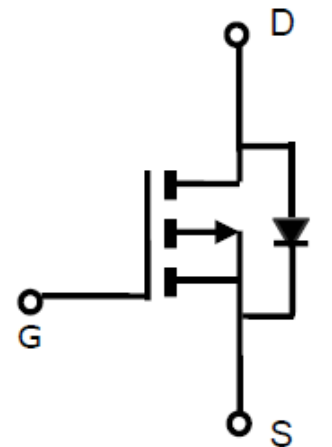

P-Channel

### ■ PART NUMBER INFORMATION

4407AA-BB C	A= Package Code S: SOP BB=Handing Code TR: Tape&Reel C=Lead Plating Code G: Green Product
-------------	--

## ORDERING INFORMATION

Part Number	Package Code	Package	Shipping
4407AS-TRG	S	SOP8	3000EA / T&R

- ※ Year Code : 0~9
- ※ Week Code : A~Z(1-26); a~z(27~52)
- ※ G : Green Product. This product is RoHS compliant.

## ABSOLUTE MAXIMUM RATINGS ( $T_A = 25^\circ\text{C}$ Unless otherwise noted )

Symbol	Parameter	Typical	Unit	
$V_{DSS}$	Drain-Source Voltage	-30	V	
$V_{GSS}$	Gate-Source Voltage	$\pm 20$	V	
$I_D$	Continuous Drain Current ( $T_A=25^\circ\text{C}$ )	$V_{GS}=10\text{V}$	-13	A
	Continuous Drain Current ( $T_A=70^\circ\text{C}$ )		-9.5	A
$I_{DM}$	Pulsed Drain Current	-40	A	
$I_S$	Continuous Source Current (Diode Conduction)	-2.0	A	
$P_D$	Power Dissipation	$T_A=25^\circ\text{C}$	2.0	W
		$T_A=70^\circ\text{C}$	1.5	
$T_J$	Operation Junction Temperature	150	$^\circ\text{C}$	
$T_{STG}$	Storage Temperature Range	-55~+150	$^\circ\text{C}$	
$R_{\theta JA}$	Thermal Resistance Junction to Ambient	85	$^\circ\text{C/W}$	

**Note: Absolute maximum ratings are those values beyond which the device could be permanently damaged. Absolute maximum ratings are stress rating only and functional device operation is not implied**

## ELECTRICAL CHARACTERISTICS ( $T_A=25^\circ\text{C}$ Unless otherwise noted)

Symbol	Parameter	Condition	Min	Typ	Max	Unit
<b>Static Parameters</b>						
$V_{(BR)DSS}$	Drain-Source Breakdown Voltage	$V_{GS}=0V, I_D=-250\mu A$	-30			V
$V_{GS(th)}$	Gate Threshold Voltage	$V_{DS}=V_{GS}, I_D=-250\mu A$	-1.0	-1.4	-2.0	V
$I_{GSS}$	Gate Leakage Current	$V_{DS}=0V, V_{GS}=\pm 25V$			$\pm 100$	nA
$I_{DSS}$	Zero Gate Voltage Drain Current	$V_{DS}=-30V, V_{GS}=0$			-1	uA
		$V_{DS}=-30V, V_{GS}=0$ $T_J=55^\circ C$			-5	
$R_{DS(on)}$	Drain-Source On-Resistance	$V_{GS}=-10V, I_D=-10A$		9.5	13	mΩ
		$V_{GS}=-4.5V, I_D=-7.0A$		14.5	17	
<b>Source-Drain Diode</b>						
$V_{SD}$	Diode Forward Voltage	$I_S=-2.3A, V_{GS}=0V$		-0.75	-1.0	V
<b>Dynamic Parameters</b>						
$Q_g$	Total Gate Charge	$V_{DS}=-15V$ $V_{GS}=-4.5V$ $I_D=-10A$		30	42	nC
$Q_{gs}$	Gate-Source Charge			10	14	
$Q_{gd}$	Gate-Drain Charge			10.4	14.6	
$C_{iss}$	Input Capacitance	$V_{DS}=-15V$ $V_{GS}=0V$ $f=1MHz$		2050	2730	pF
$C_{oss}$	Output Capacitance			506	710	
$C_{riss}$	Reverse Transfer Capacitance			420	590	
$T_{d(on)}$	Turn-On Time	$V_{DS}=-15V$ $I_D=-10A$		9.3	19	nS
$T_r$				10.2	18	
$T_{d(off)}$	Turn-Off Time	$V_{GEN}=-10V$ $R_G=3.3\Omega$		117	232	
$T_f$				24	46	

**Note: 1. Pulse test: pulse width $\leq$ 300uS, duty cycle $\leq$ 2%**

**2.Static parameters are based on package level with recommended wire bonding**

## ■ TYPICAL CHARACTERISTICS (25 °C Unless Note)

**Output Characteristics**

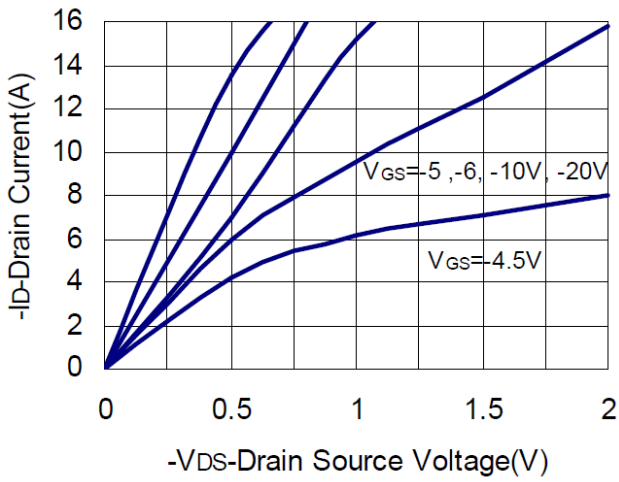

**Transfer Characteristics**

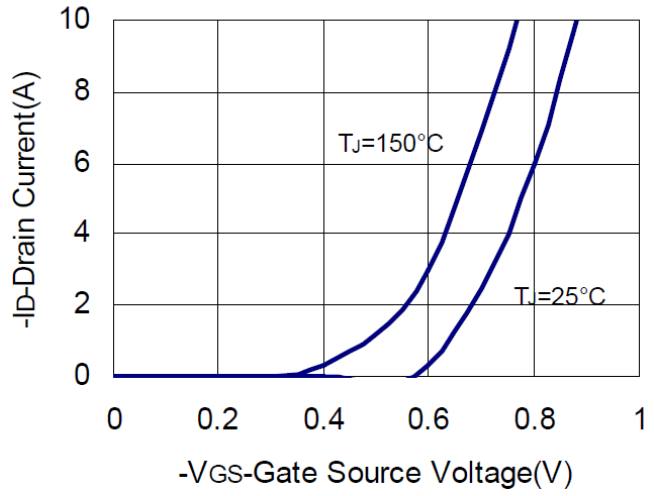

**Drain Source On Resistance**

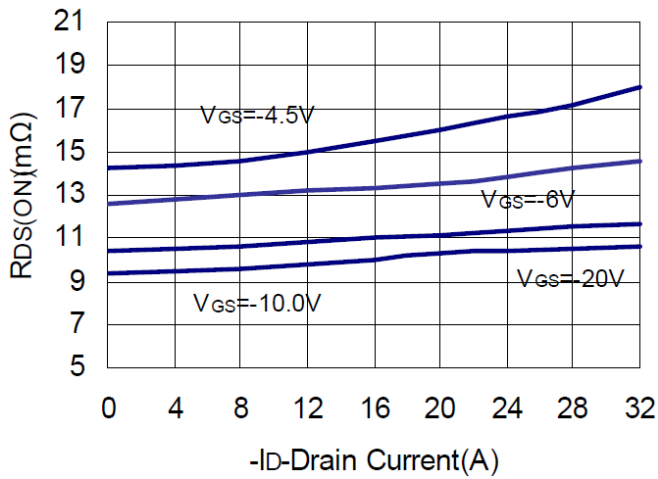

**Gate Threshold Voltage**

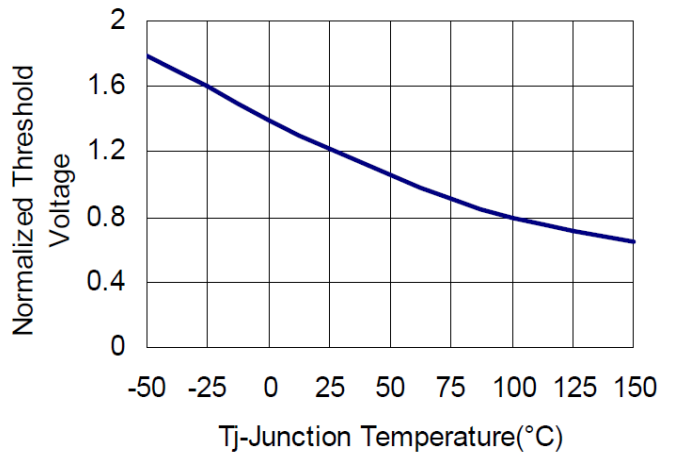

**Gate Charge**

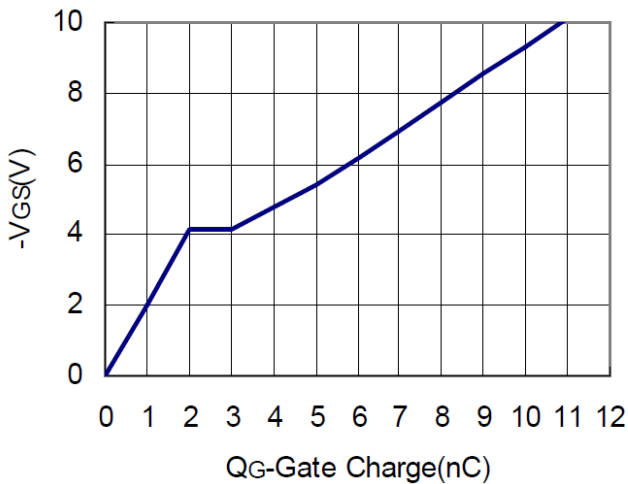

**Drain Source Resistance**

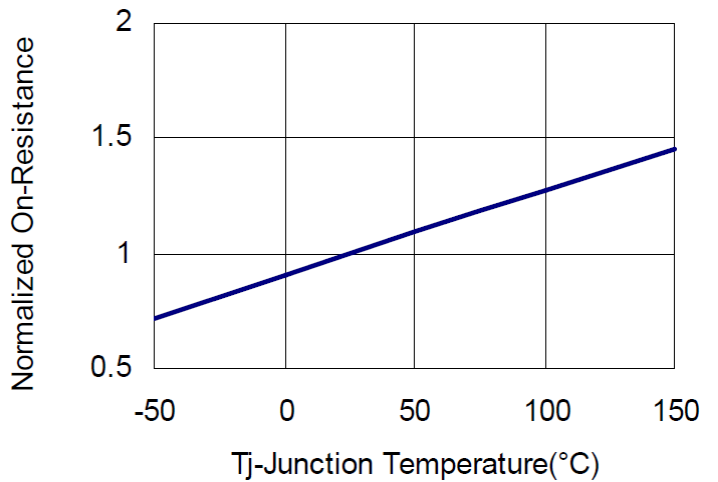

■ **TYPICAL CHARACTERISTICS** (continuous)

**Source Drain Diode Forward**

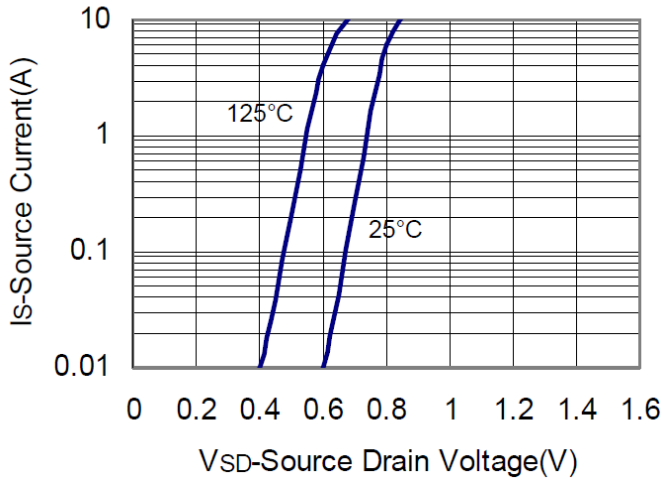

**Capacitance**

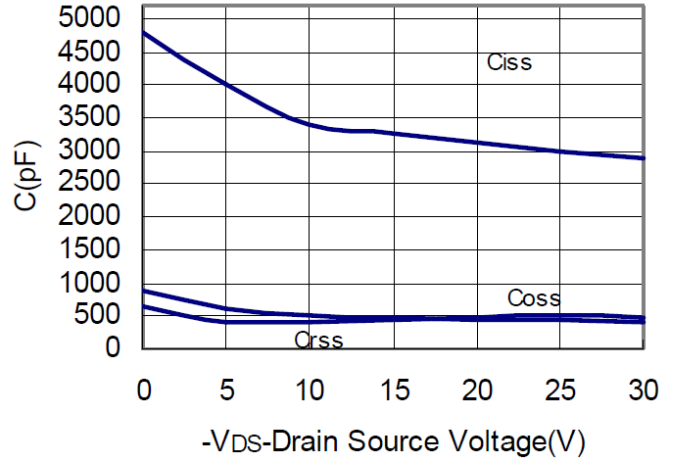

**Power Dissipation**

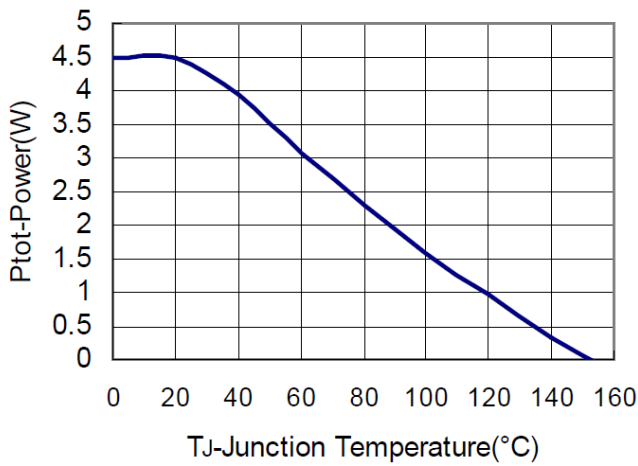

**Drain Current**

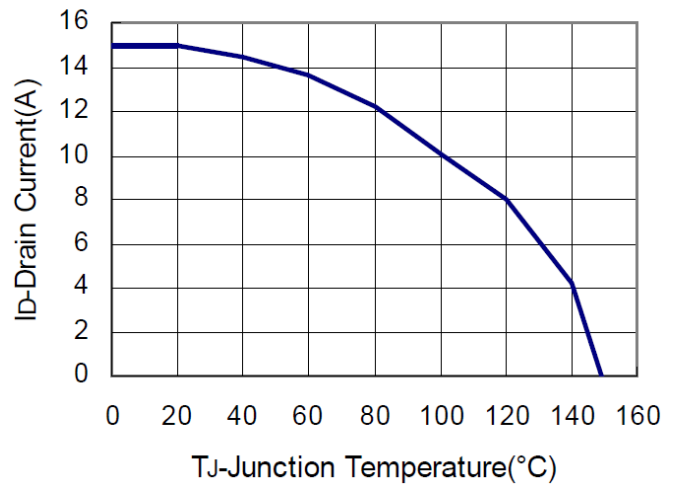

**Thermal Transient Impedance**

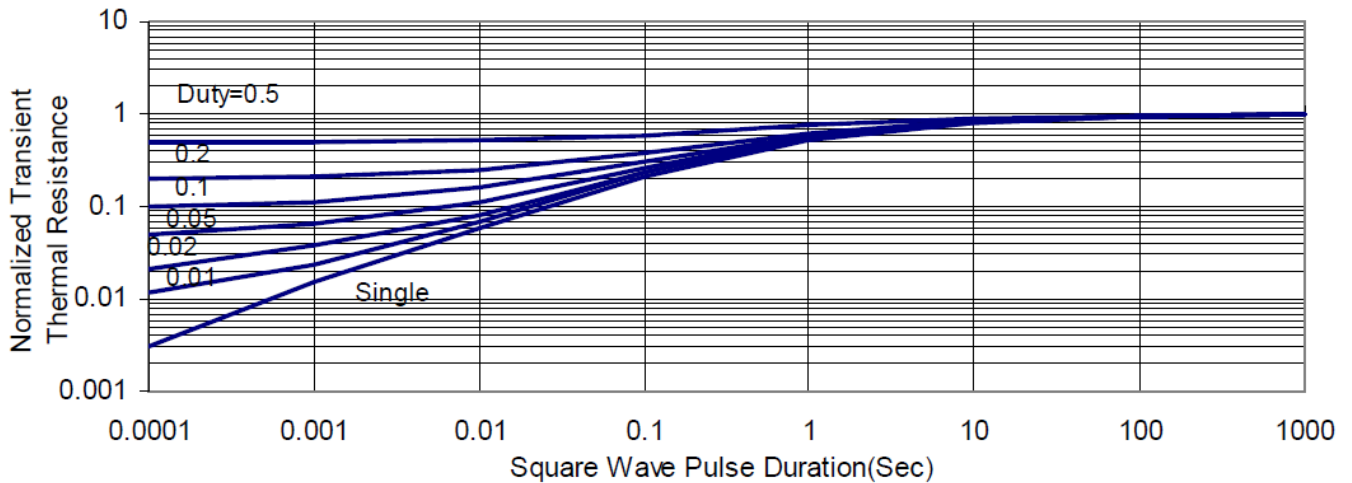

## ■ SOP8 PACKAGE OUTLINE DIMENSIONS

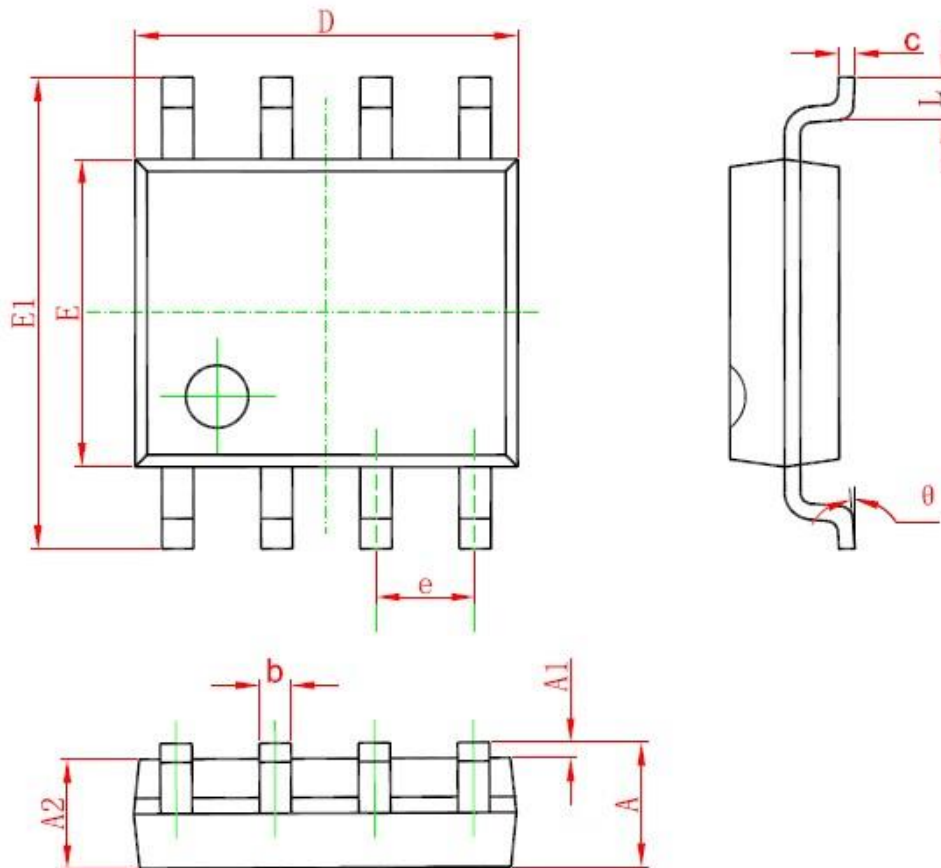

Symbol	Dimensions In Millimeters		Dimensions In Inches	
	Min	Max	Min	Max
A	1.350	1.750	0.053	0.069
A1	0.100	0.250	0.004	0.010
A2	1.350	1.550	0.053	0.061
b	0.330	0.510	0.013	0.020
c	0.170	0.250	0.006	0.010
D	4.700	5.100	0.185	0.200
E	3.800	4.000	0.150	0.157
E1	5.800	6.200	0.228	0.244
e	1.270 (BSC)		0.050 (BSC)	
L	0.400	1.270	0.016	0.050
θ	0°		8°	

## ■ SOLDERING METHODS FOR UNIVERCHIP

Storage environment Temperature=10°C~35°C Humidity=65%±15%  
 Reflow soldering of surface mount device

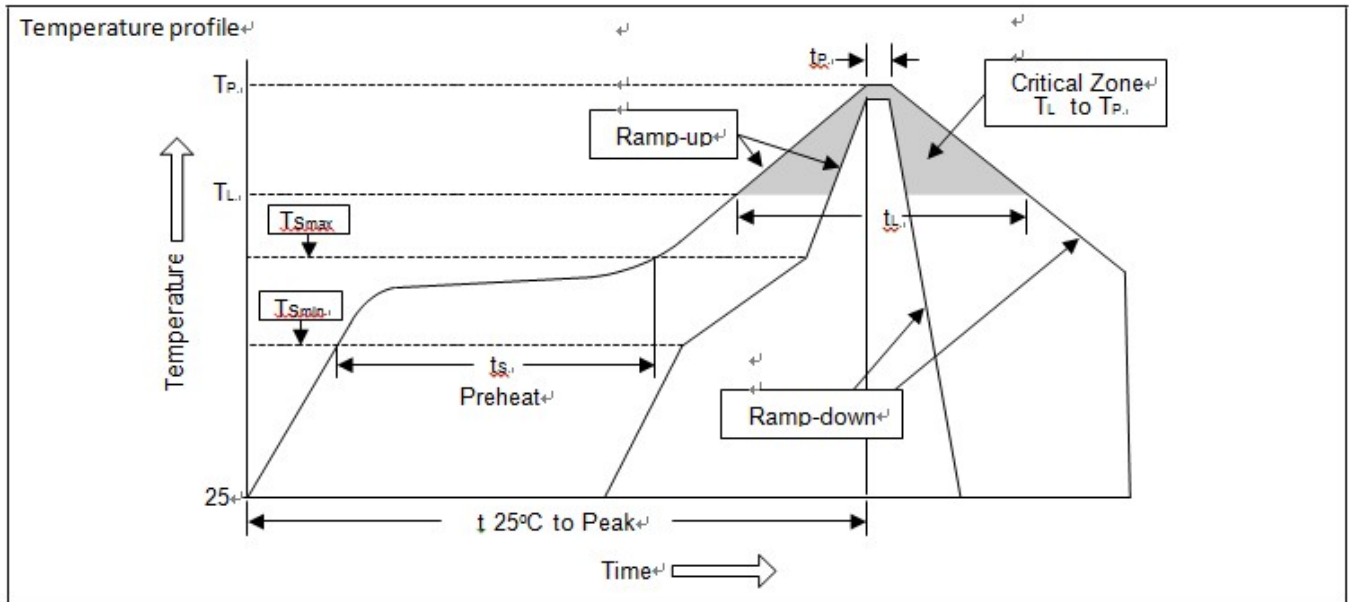

Profile Feature	Sn-Pb Eutectic Assembly	Pb free Assembly
Average ramp-up rate ( $T_L$ to $T_P$ )	<3°C/sec	<3°C/sec
Preheat		
-Temperature Min ( $T_{Smin}$ )	100°C	150°C
-Temperature Max ( $T_{Smax}$ )	150°C	200°C
-Time (min to max) ( $t_s$ )	60~120 sec	60~180 sec
$T_{Smax}$ to $T_L$		
-Ramp-up Rate	<3°C/sec	<3°C/sec
Time maintained above		
-Temperature ( $T_L$ )	183°C	217°C
-Time ( $t_L$ )	60~150 sec	60~150 sec
Peak Temperature ( $T_P$ )	240°C+0/-5°C	260°C+0/-5°C
Time within 5°C of actual Peak Temperature ( $t_p$ )	10~30 sec	20~40 sec
Ramp-down Rate	<6°C/sec	<6°C/sec
Time 25°C to Peak Temperature	<6 minutes	<6 minutes

Flow (wave) soldering (solder dipping)

Product	Peak Temperature	Dipping Time
---------	------------------	--------------

Pb device	245°C±5°C	5sec±1sec
Pb-Free device	260°C +0/-5°C	5sec±1sec



This integrated circuit can be damaged by ESD. UniverChip Corporation recommends that all integrated circuits be handled with appropriate precautions. Failure to observe proper handling and installation procedure can cause damage. ESD damage can range from subtle performance degradation to complete device failure. Precision integrated circuits may be more susceptible to damage because very small parametric changes could cause the device not to meet its published specifications.