

TO-252/TO-251 Plastic-Encapsulate Voltage Regulators

L7905 Three-terminal negative voltage regulator

FEATURES:

※ Maximum output current

IOM: 1.5A

※ Output voltage

VO: -5V

※ Continuous total dissipation

PD: 1.25W

MARKING:

7905 D / U ****

logo (D→252) / (U→251) ****→Date

TYPICAL APPLICATION:

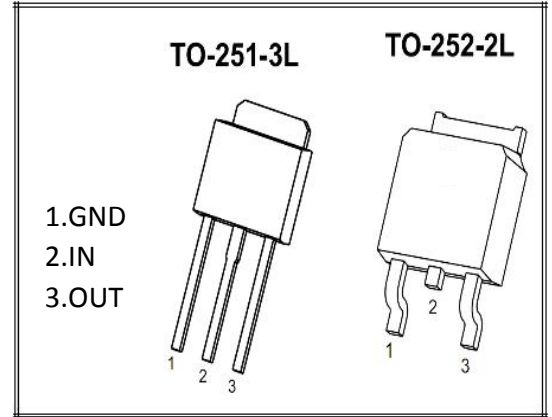
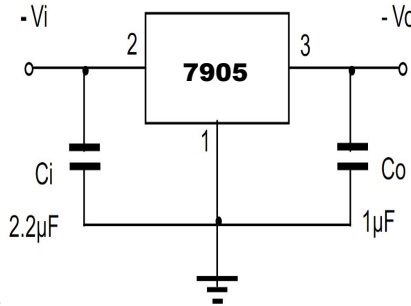

Absolute Maximum ratings (Operating temperature range applies unless otherwise specified)

Parameter	Symbol	Value	Unit
Input Voltage	Vi	-35	V
Thermal Resistance From Junction to air	RθJA	100	°C/W
Operating Junction Temperature Range	TOPR	-25~+125	°C
Storage Temperature Range	TSTG	-55~+150	°C

Electrical Characteristics At Specified Virtual Junction Temperature

(Vi=-10V, Io=500mA, Ci=0.33µF, Co=0.1µF. Unless Otherwise Specified)

Parameter	Symbol	Test Condition	Min	Typ	Max	Unit	
Output voltage	VO	25°C	-4.8	-5	-5.2	V	
		-7V≤Vi≤-20V, Io=5mA-1A	-25~+125	-4.75	-5	-5.25	V
Load Regulation	ΔVO	Io=5mA-1.5A, Vi=-10V	25°C		15	100	mV
		Io=250mA-750mA, Vi=-10V	25°C		5	50	mV
Line Regulation	ΔVO	-10.5V≤Vi≤-25V, Io=250mA	25°C		13	100	mV
		-11V≤Vi≤-25V, Io=250mA	25°C		4	50	mV
Quiescent Current	Iq	25°C		2	6	mA	
Quiescent Current Change	ΔIq	-10.5V≤Vi≤-25V, Io=250mA	-25~+125			0.8	mA
		5mA≤Io≤1A	-25~+125			0.5	mA
Output Noise Voltage	VN	10Hz≤f≤100KHz	25°C		125	200	µV/Vo
Ripple Rejection	Rr	-11.5V≤Vi≤-21.5V, f=120Hz, Io=300mA	-25~+125	54	60		dB
Dropout Voltage	Vd	Io=1A	25°C		1.5	2.5	V
Short Circuit Current	Isc	Vi=-10V	25°C		250		mA
Peak Current	IPK	25°C		2.2			A
Output Voltage Drift	ΔVO/ΔT	Io=5mA	25°C		-0.5		mV/°C

Note : Bypass Capacitors are Recommended For Optimum Stability and Transient Response and Should be located as Close as Possible to the Regulators

Package Dimensions:

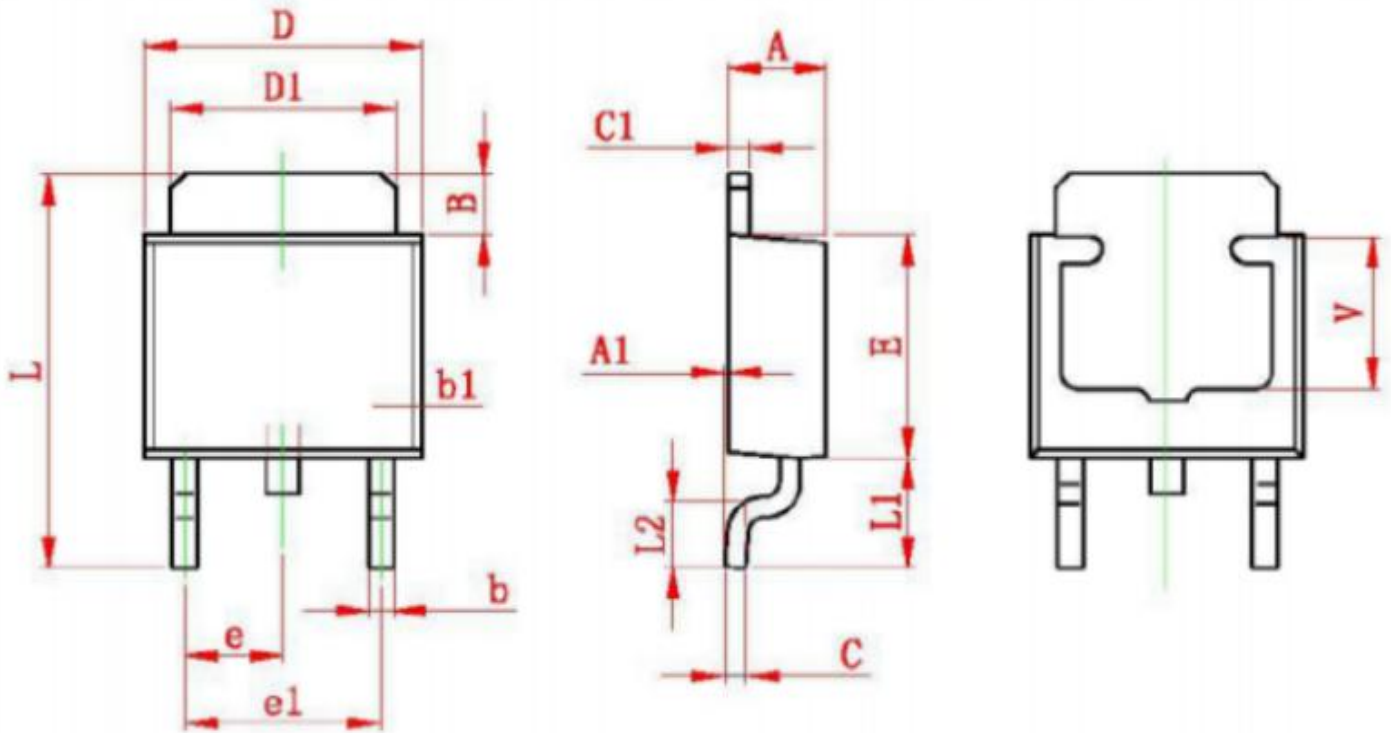

Symbol	Dimensions In Millimeters		Dimensions In Inches	
	Min	Max	Min	Max
A	2.200	2.400	0.087	0.094
A1	0.000	0.127	0.000	0.005
B	1.350	1.650	0.053	0.065
b	0.500	0.700	0.020	0.028
b1	0.700	0.900	0.028	0.035
c	0.430	0.580	0.017	0.023
c1	0.430	0.580	0.017	0.023
D	6.350	6.650	0.250	0.262
D1	5.200	5.400	0.205	0.213
E	5.400	5.700	0.213	0.224
e	2.300 TYP		0.091 TYP	
e1	4.500	4.700	0.177	0.185
L	9.500	9.900	0.374	0.390
L1	2.550	2.900	0.100	0.114
L2	1.400	1.780	0.055	0.070
V	3.80 REF		0.150 REF	

Package Dimensions:

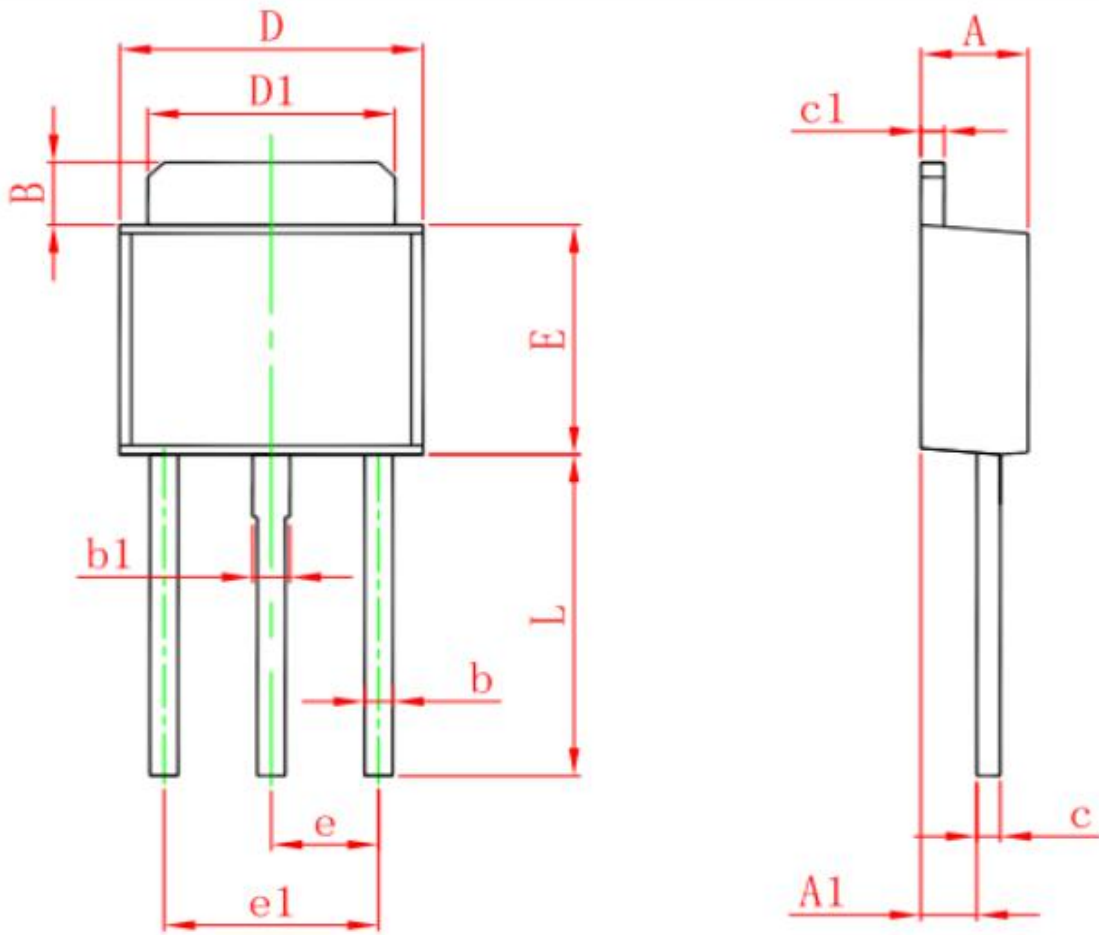

Symbol	Dimensions In Millimeters		Dimensions In Inches	
	Min.	Max.	Min.	Max.
A	2.200	2.400	0.087	0.094
A1	1.050	1.350	0.042	0.054
B	1.350	1.650	0.053	0.065
b	0.500	0.700	0.020	0.028
b1	0.700	0.900	0.028	0.035
c	0.430	0.580	0.017	0.023
c1	0.430	0.580	0.017	0.023
D	6.350	6.650	0.250	0.262
D1	5.200	5.400	0.205	0.213
E	5.400	5.700	0.213	0.224
e	2.300 TYP.		0.091 TYP.	
e1	4.500	4.700	0.177	0.185
L	7.500	7.900	0.295	0.311